

Installation Instructions

Nocturne™ 220V Exterior Projection Screen by Draper

⚠ Caution

- ① Inspect all boxes to make sure you have received the proper parts.
- ② Open cartons lengthwise.
- ③ All hardware must be installed level. Screens must be level and square.
- ④ Do not wire motors in parallel without written permission from Draper.
- ⑤ It is the installer's responsibility to make sure appropriate fasteners are used for mounting surface.
- ⑥ **Please read the following installation guidelines thoroughly and follow them carefully. Failure to do so may cause product to fall or otherwise fail, and invalidates warranty.**

Before mounting your Nocturne Exterior Projection Screen, mark building for placement of mounting brackets and pre-drill mounting holes and electrical access holes (if necessary) in mounting surface. It is installer's responsibility to make sure appropriate fasteners are used for mounting surface. The Nocturne Exterior Projection Screen is shipped with screen case assembly complete (see Fig. 1).

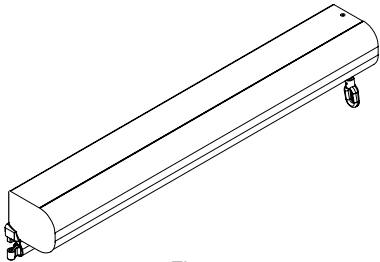

Figure 1

Mounting Through Back of Screen Case:

- ① Remove fascia from screen case. If your unit is equipped with a crank operator, first remove the crank attachment from the unit, then remove additional screws holding fascia onto back/top and rotate fascia up and off of unit (see Fig. 2).

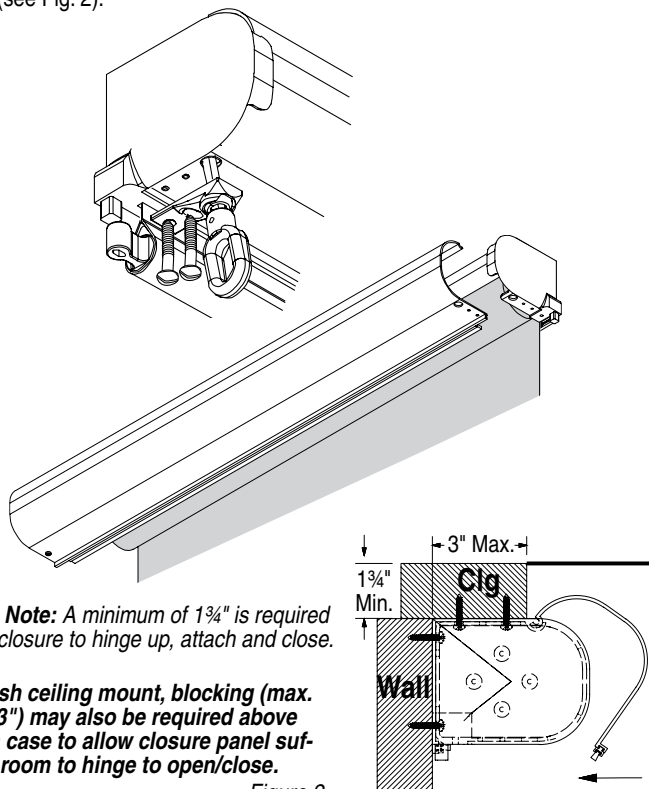
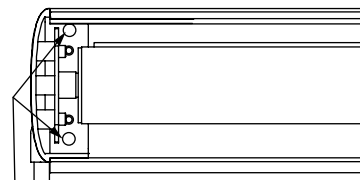

Figure 2

Please Note: A minimum of 1 3/4" is required for the closure to hinge up, attach and close.

For flush ceiling mount, blocking (max. depth 3") may also be required above screen case to allow closure panel sufficient room to hinge to open/close.

- ② Drill mounting holes in back of screen case, using holes in endcaps for guides. Holes can also be drilled through the sides of the endcaps for inside mounting (see Fig. 3). If this is a motorized unit, you will also need to drill out a hole for the power and control cable to exit the screen case.



Drill holes for wall mounting, using holes in endcaps as guides.

Figure 3

Please Note: It is the installer's responsibility to make sure appropriate fasteners are used for mounting surface.

Mounting Through Top of Screen Case:

- ① Remove fascia from screen case. If your unit is equipped with a crank operator, first remove the crank attachment from the unit, then remove additional screws holding fascia onto back/top and rotate fascia up and off of unit (see Fig. 2).
- ② Remove screen assembly from screen case. If motorized, remove motor retaining clips. Pull the screen assembly away from the operator end. This will depress the spring-loaded pin on the non-operator end. Then you can rotate screen assembly out of the screen case (Fig. 4).

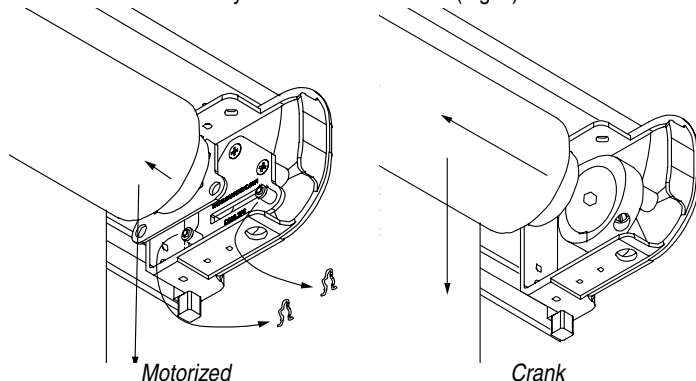

Figure 4

Please Note: A minimum of 1 3/4" is required for the closure to hinge up, attach and close.

- ③ Drill mounting holes in top of screen case, using holes in endcaps for guides. If this is a motorized unit, you will also need to drill out holes for the power and control cables to exit the screen case.

Please Note: It is the installer's responsibility to make sure appropriate fasteners are used for mounting surface.

- ④ Replace screen assembly in screen case. Place the spring-loaded pin on the non-operator end into the endcap. Push the screen assembly toward the non-operator end to depress the spring-loaded pin, then rotate screen assembly into the screen case.
- ⑤ Lower viewing surface approximately 12" to begin guide installation.
- ⑥ If motorized, replace motor retaining clips (see Fig. 4).

Side Cable Installation (see Fig. 5 on page 2):

Please Note: Skip this section if you elect not to install the side cable guides.

- ① Attach cable deck or wall mount to mounting surface.
- ② Attach cable to deck or wall mount using provided washer and nut.
- ③ After making sure of the length required, cut cable and strip the protective jacket from the top 1".
- ④ Insert cable through the hole provided in the end of the dowel, and then up through hole in endcap.
- ⑤ Insert stripped-off portion of cable into provided screw jacket, then tighten in place against the side wall of the endcap with the provided screw. Make sure the cable is taut. Tension to 8 in-lbs, so the screen will move up and down easily along the cable.
- ⑥ Replace fascia and crank operator (if provided).

DRAPER

411 S. Pearl St., Spiceland, IN 47385 USA ■ 765-987-7999

www.draperinc.com ■ fax 765-987-7142

Copyright © 2015 Draper Inc. Form Nocturne_220V_Inst15 Printed in U.S.A.

Continued on next page

If you encounter any difficulties installing or servicing your Nocturne Exterior Projection Screen call your dealer or Draper, Inc. in Spiceland, Indiana, 765-987-7999, or fax 765-987-7142.

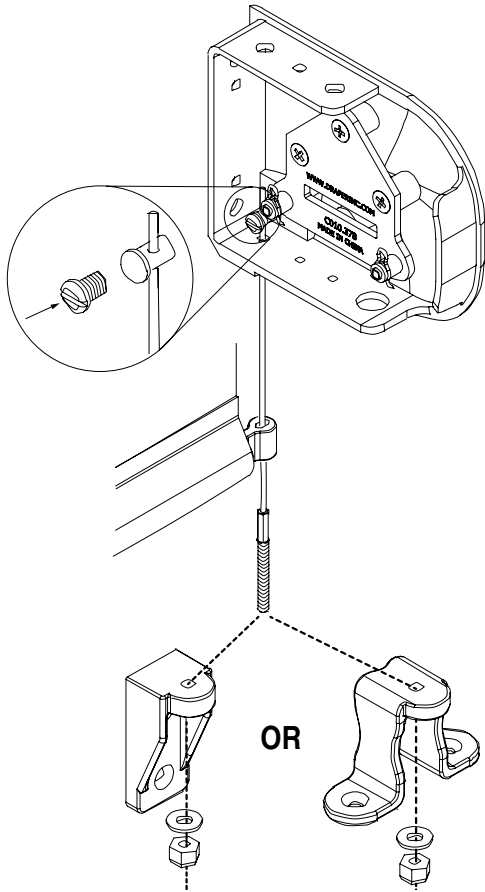

Figure 5

Electrical Connections

Screen operates on 220V, 50Hz. or 60 Hz. 1 ph. current. Screen is shipped with internal wiring complete and control switch (es) fully boxed, and supplied with a 6' cable lead. Longer lead can be substituted by removing two screws in motor end of roller, removing lead, plugging new lead in, and replacing screws. Wire to connect shade to switch (es) and switch (es) to power supply should be furnished by installer. Connections should be made in accordance with attached wiring diagram, and wiring should comply with national and local electrical codes. **DO NOT wire motors in parallel without written permission from Draper.**

All operating switches should be "off" before power is connected.

Limit Switch Adjustments—Standard Motor

Please Note: Screen limits are factory set for optimum performance of the screen. A procedure is outlined below for minor tweaks, but any adjustment of these limits may negatively affect the flatness of the screen surface and could also void the warranty. Please check with Draper prior to resetting screen limits.

⚠ CAUTION: Always be prepared to shut screen off manually when new adjustment is being tested. Screen may be severely damaged if viewing surface is allowed to run too far up or too far down.

⚠ CAUTION: Be sure all switches are in "off" position before adjusting limit switches.

Push Button Limits

- ① Fully depress both limit switch push buttons, then operate wall switch to make sure system works properly.
- ② Raise screen to desired "up" stop position.
- ③ Set upper limit by depressing and releasing the proper (back) push button.
- ④ Lower screen to desired "down" stop position.
- ⑤ Set lower limit by depressing and releasing the proper (front) push button.

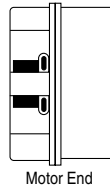

Motor End

Screw-Type Limits

- ① Determine which direction of travel corresponds with arrows on motor.
- ② Operate screen to desired "down" stop position. Set limit by turning the proper socket toward the "+" to lower the limit, and "-" to raise it.
- ③ Operate screen to desired "up" stopping position. Set limit by turning the proper screw toward the "-" to raise the limit, and "+" to lower it.

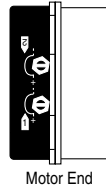

Motor End

Nocturne Exterior Projection Screen—Crank and Motorized Dimensions

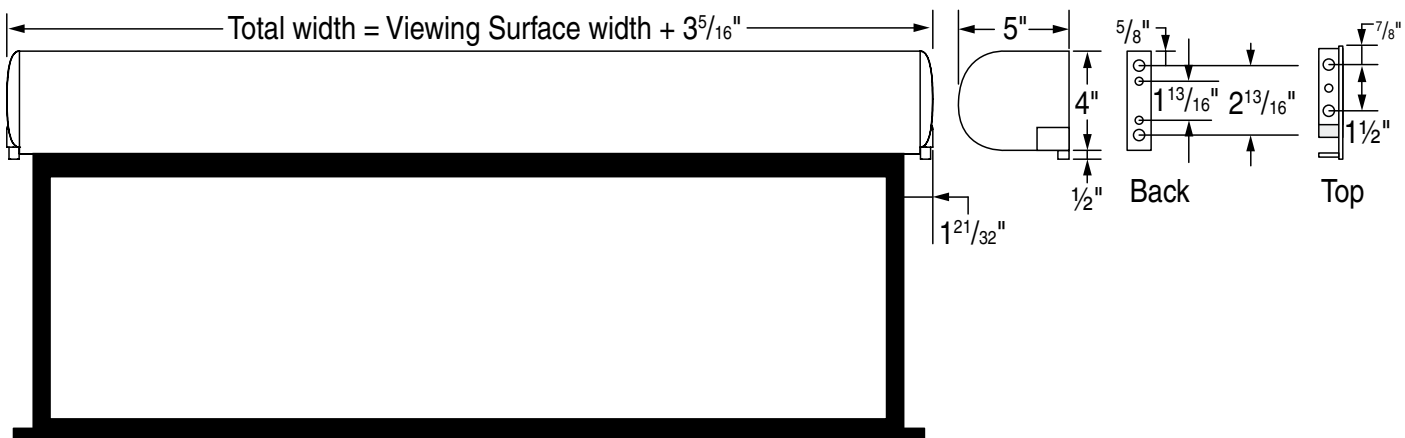

Wiring Diagrams—220V Standard Motor Schaltpläne—220 V Standardmotor Schémas de câblage : moteur standard 220 V

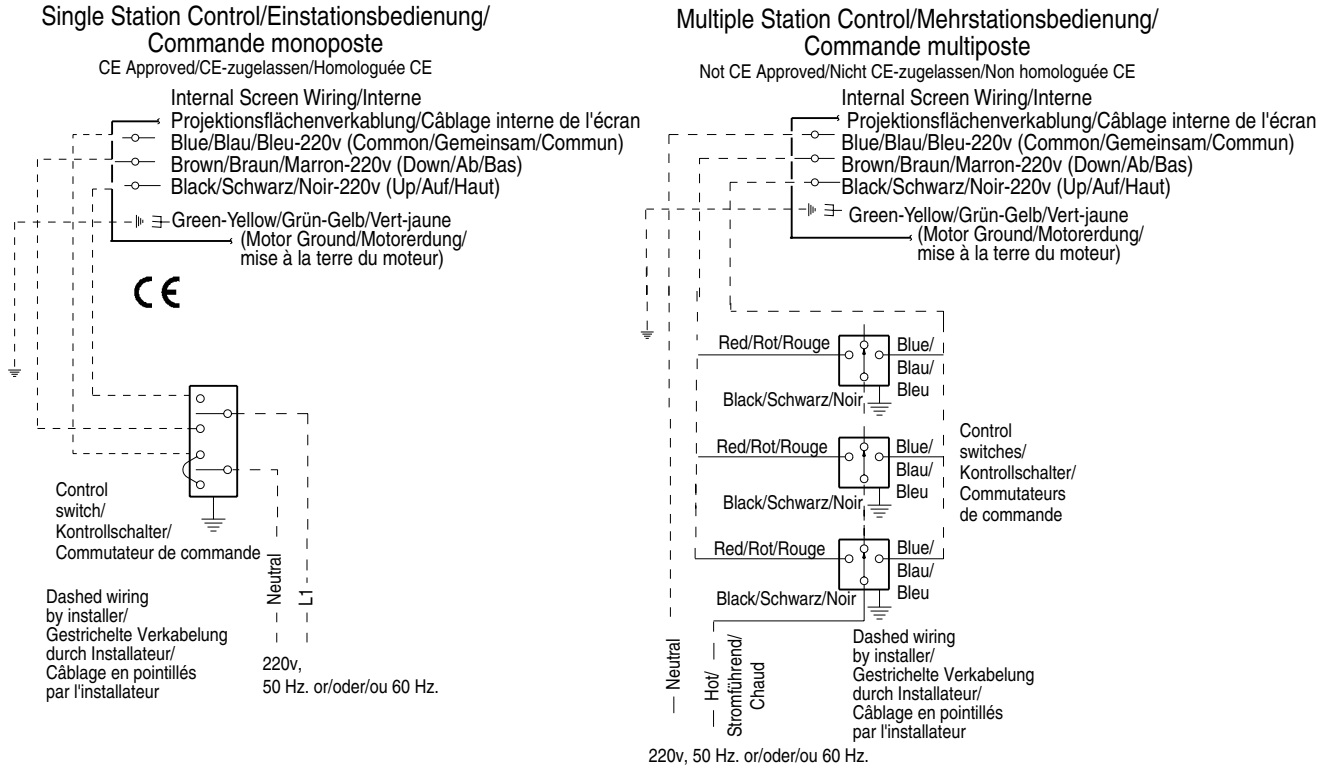

Please Note: Do not wire motors in parallel/ Bitte beachten: Motoren nicht parallel schalten Remarque: Ne pas connecter les moteurs en parallèle.

External Low Voltage and Wireless Externe Niederspannung und kabellos Basse tension externe et sans fil

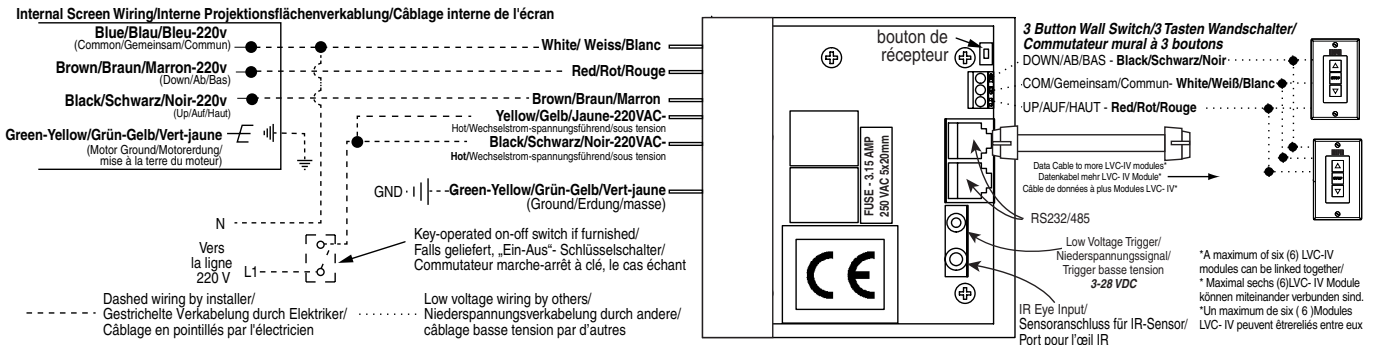

RTS Motor/Remote Programming Instructions

If you receive a Nocturne with an optional RTS motor from Draper, Inc., the motor has no programming on it, so it must be learned and programmed to work on the transmitter that you have. The limits must also be set. Here are the initial programming instructions.

- 1 Connect power to motor. Select the transmitter/channel to which you plan to learn the motor. Press and hold the UP and DOWN buttons at the same time until the motor jogs, then release.

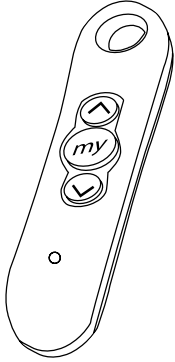

- 2 Check the motor run direction by press either the UP or DOWN buttons. This is important because if you do step 3 without doing this step, then you will need to reset the motor. If you need to reverse the motor direction, then press the STOP button (middle button which might be labeled MY) for 5 seconds until the motor jogs. Check the direction again to make sure that it works.
- 3 Move the motor to its upper limit position. Press the STOP and DOWN buttons at the same time until the motor starts to move down, then release. You will stop the motor at its lower limit. You can use the UP and DOWN buttons to adjust the motor to the correct lower limit position if need be.
- 4 Once the motor is at its lower limit position, then press the UP and STOP buttons at the same time until the motor starts to move up, then release. The motor should move to the upper limit position in step 3 and stop.
- 5 Once the motor has stopped at its upper limit position, then press and hold the STOP button for 5 seconds until the motor jogs.
- 6 Now, you must put the motor into USER mode. Find the programming button which is a small button on the back or side of the transmitter and press it until the motor jogs. Once you have done this, then the motor will operate in normal fashion.

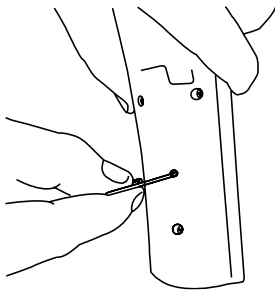

- 7 Disconnect power to this motor and move to the next in your installation and start with step 1. Reconnect motor to power when all motors are programmed.

Reset Motor Instructions

If the motor is not working or responding correctly and you want to reprogram it from the beginning and clear all previous programming, then follow these steps.

- 1 Disconnect the motor from power for 2-5 seconds, reconnect to power for 10-13 seconds, disconnect from power for 2-5 seconds, and reconnect to power. The motor should move down a little after you reconnect to power the last time.

- 2 You will then need to find the programming button which is a small button on the back or side of the transmitter. You will need to depress the button for 10-15 seconds. The motor should jog up and down once then pause and jog a second time during this time period. Once the motor has completed its second jog, then you can start at step 1 of initial programming as the motor is clear.

Add/Delete a Channel/Transmitter

Add:

- 1 Select the channel/transmitter that is currently operating the motor, then press the programming button until the motor jogs.
- 2 Select the new channel/transmitter that you want to add to the motor, then press the programming button until the motor jogs.

Channel selector button on Multi-Channel Transmitter

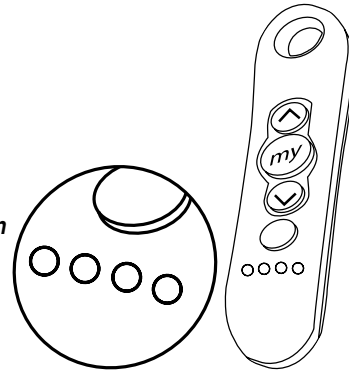

- 3 The motor should now work on both the old and new channel/transmitter.

Delete:

- 1 Select the channel/transmitter that is currently operating the motor and you want to keep, then press and hold the programming button until the motor jogs.
- 2 Select the channel/transmitter that you want to remove, then press and hold the programming button until the motor jogs.
- 3 The motor should now only work on the channel/transmitter from step 1.

Adjust Limits in User Mode

If your initial limits have changed or you want to fine tune a motor, you do not need to reset the motor and re-program it. You can just change the limits with these steps.

- 1 Move the motor to the limit (upper or lower) that you want to change.
- 2 Press and hold the UP and DOWN buttons until the motor jogs.
- 3 Move the motor to its new limit location.
- 4 Press and hold the STOP button until the shade jogs.